

## Technical Information

Specification	DigiCreaser
---------------	-------------

MAX. SHEET SIZE .....	25.5" x 13"
MIN. SHEET SIZE .....	5.5" x 6.2"
MAX. PAPER WEIGHT .....	150+lb cover stock Including Laminated Material
MIN. PAPER WEIGHT .....	20 lb Bond
MAX. NO. CREASES PER SHEET .....	9
MAX. NO. PROGRAMMED APPLICATIONS .....	6
INDIVIDUAL CREASE ADJUSTMENT .....	0.003"
SPEED PER HOUR (8.5" x 11") .....	4000 sph (depending on operator)

(Note: The production speed varies according to material size and the number of creases on the sheet)

DIMENSIONS .....L: 34.2" x W: 22.4" x H: 23.2" (42.1" on optional base)

WEIGHT .....132lbs (176lbs on optional base)

POWER REQUIREMENT .....110v 60hz

*Morgana*

**A GUARANTEED UPGRADE PATH**

## TO THE FINEST IN CREASING TECHNOLOGY WITH GUARANTEED BUY-BACK!

From the entry level Docu-Crease through to the DocuMaster total finishing system, Morgana offers efficient and cost effective solutions to all digital finishing requirements. And to ensure that customers have a clear UPGRADE PATH to meet future finishing needs, Morgana also operates a guaranteed buy-back plan on all creasing products.

**Docu-Crease™**  
Quality hand creasing  
in 14" & 20" sizes



**Electro-Creaser™**  
Semi-automatic for  
single or multiple  
creases. Also 14"  
& 20" sizes

**DigiCreaser™**  
Brand new creaser filling  
the gap between semi  
and fully automatic  
systems



**AutoCreaser™**  
Now in AutoCreaser 33  
and AutoCreaser 50  
versions - the latter  
taking larger sizes  
and operating faster  
than the original  
best-seller

**DigiFold™**  
Morgana's unique  
combination of  
patented creasing  
& folding  
techniques in  
one unit



**DocuMaster**  
A fully  
intelligent  
feeder, creaser &  
bookletmaker  
taking work direct  
from the digital  
printer

FAST, ACCURATE  
AND THE BEST VALUE  
QUALITY CREASER  
YOU CAN BUY



MORGANA  
DigiCreaser

*Morgana*

Morgana Systems Ltd  
3909 Upland Way, Marietta  
GA 30066, USA  
Tel: 866 463 5060 Fax: (770) 565 6163

Web: [www.morganausa.com](http://www.morganausa.com)  
Email: [morganausa@comcast.net](mailto:morganausa@comcast.net)

**1** in  
Number Digital  
Print  
Finishing

Morgana Systems Ltd  
3909 Upland Way, Marietta, GA 30066, USA  
Tel: 866 463 5060 Fax: (770) 565 6163  
[www.morganausa.com](http://www.morganausa.com)

*Morgana*

THE FIRST NAME IN DOCUMENT FINISHING SOLUTIONS



# NEED FAST THROUGHPUT BUT DON'T HANDLE THE VOLUMES TO JUSTIFY A SUCTION FEED CREASER?.....THEN THE DIGICREASER WAS MADE FOR YOU!

The Morgana manufactured DigiCreaser fills the gap between our semi-automatic machines and fully automatic machines like the best selling AutoCreaser.

Whilst its cost is little over half that of an AutoCreaser, it offers exactly the same creasing quality and accuracy. This is because it uses an identical matrix and rule action, with the same technology to control both the positioning of the creases, but also to give a completely consistent creasing depth. With the rule and matrix manufactured from high quality tooled steel we can guarantee this mechanism for life.

And the DigiCreaser is no slouch when it comes to productivity. All functions are fully automatic after feeding and the unit can operate at speeds up to 4,000 sheets per hour. Up to 9 creases can be achieved in one pass and the sophisticated controls enable jobs to be stored and retrieved for repeat work.

The class leading specification of the DigiCreaser includes a maximum sheet size of 25.5" x 13" and it will handle weights of stock up to 400gsm.

**Head-up display** for greater ease of use. This is particularly intuitive as it provides the operator with a series of prompts which are actioned by a single controller. These include positioning of the creases, setting the speed of the machine, storing jobs and counting facility.



**Standard features** includes the same high quality perforating as the larger AutoCreasers. The perfering wheels are available with a variety of teeth to suit all applications. In instances where the crease has to be set to an image which is not correctly registered you can swing the rule/matrix mechanism to compensate. The speed at which the sheets are taken into the in-put rollers can also be adjusted.

The DigiCreaser can be supplied as either a bench top or floor standing model.

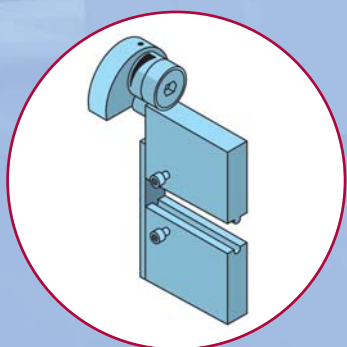

**Creasing rule and matrix.** The DigiCreaser uses an identical mechanism to that on the more expensive AutoCreaser and DocuMaster and is guaranteed for life. With thousands of these mechanisms installed throughout the world our creasing technology is unparalleled in both performance and longevity.

From entry level manual creasers, through semi and fully automatic models and then to multi-function machines such as the DigiFold and DocuMaster, Morgana offers efficient and cost effective solutions to all digital finishing needs. And to ensure that customers have a clear upgrade path to meet future requirements, we offer a **GUARANTEED BUY-BACK** plan on all our creasing products.

**DigiCreaser - part of Morgana's Guaranteed Upgrade Path To The finest in Creasing Technology - With Guaranteed Buy-Back**

# THE DIFFERENCE IS CLEAR

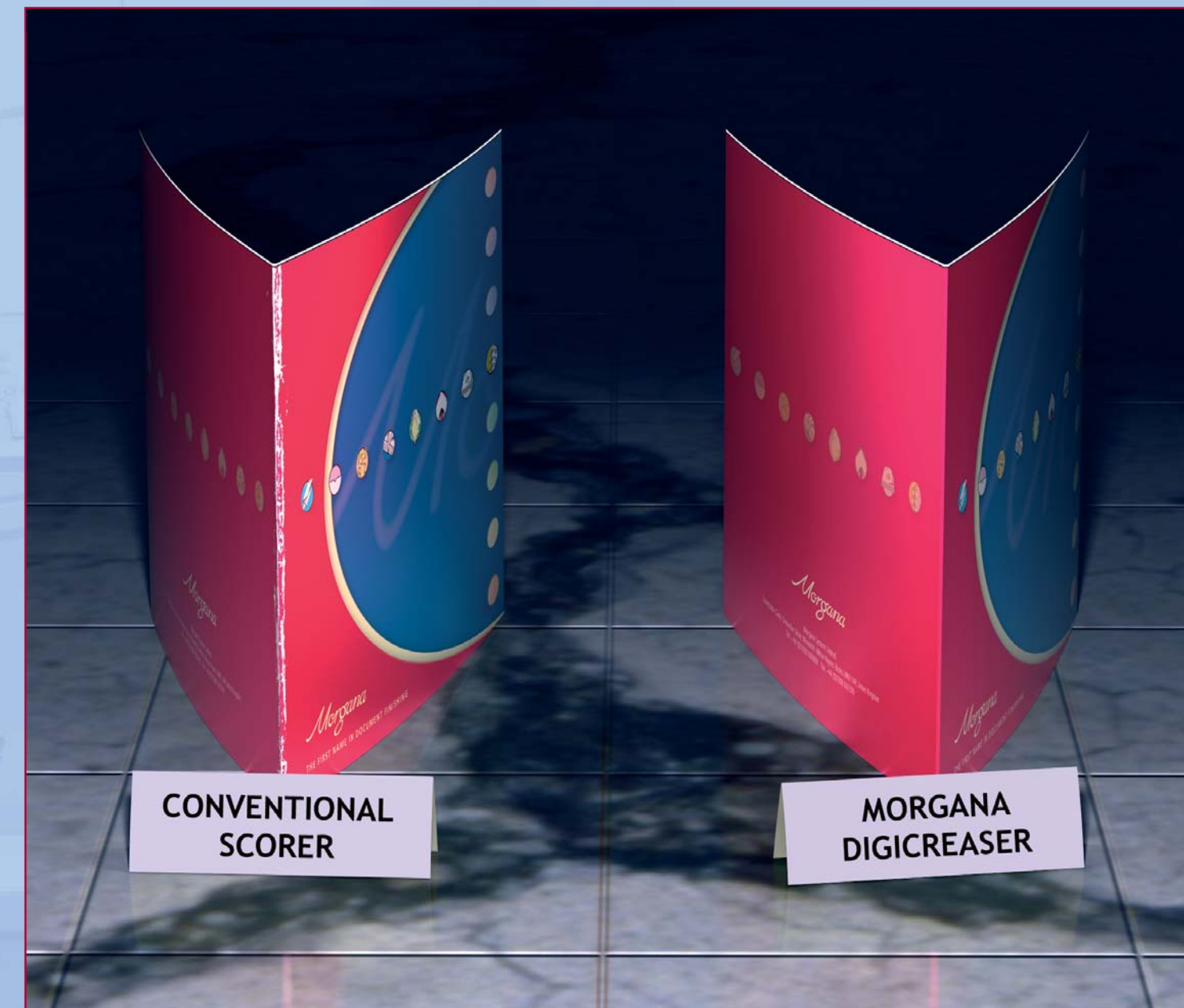

## Creasing versus Scoring

Traditional rotary scoring machines use circular blades that are in constant motion as the stock passes through them. This creates a ploughing action that actually cuts through the top fibres of the paper or card in order to create a score. Inevitably this weakens the paper and encourages cracking.

In contrast, the Morgana DigiCreaser employs a unique creasing rule and matrix - as illustrated - that eliminates tearing and, therefore, cracking.

*Morgana*

**Number 1 in Digital Print Finishing**