

Specifications

Configuration	Freestanding cabinet with castors
Cutting method	Programmable fixed long blade (paper feed direction) and interchangeable rotary blade unit (paper width direction)
Finished size	Business card, Postcard, and adjustable custom sizes
Paper size	12" x 18" & 12.2" x 19.2"
Thickness and weight	* From 0.0048" (70lbs text or 6pt approximately) up to 0.016" (130lbs cover or 16pt approximately)
Number of sheets or pages	A 12" x 18" sheet when cut yields one of the following; 20 x Business cards, 8 x Postcards
Cutting speed	7 sheets per minute (20 business cards on a 12" x 18" sheet)
Paper feed	500 sheets of paper in a single stack (for 0.0048" thick) Air suction paper feed system.
Paper output	Natural separation method, up to 650 sheets of paper stacked in each row (for 0.0048" thick) Waste bin included.
Dimensions	40"(W) x 24"(D) x 36"(H)
Weight	Approx. 154lbs
Power supply	Universal 100 - 240V AC±10%, 1.5 - 0.7A, 50/60Hz
Operating environment	10 - 32°C, or 50 - 89.6°F, 20 to 80% RH (no condensation permitted)
Noise	65dB or less
Safety Regulations	CE Mark (EN 60950 EN55014)

* Depending on type of stock and imaging device being used. Always check your stocks are suitable prior to purchase. The specification is measured on plain un-imaged stock. Results achieved on imaged stocks may vary.

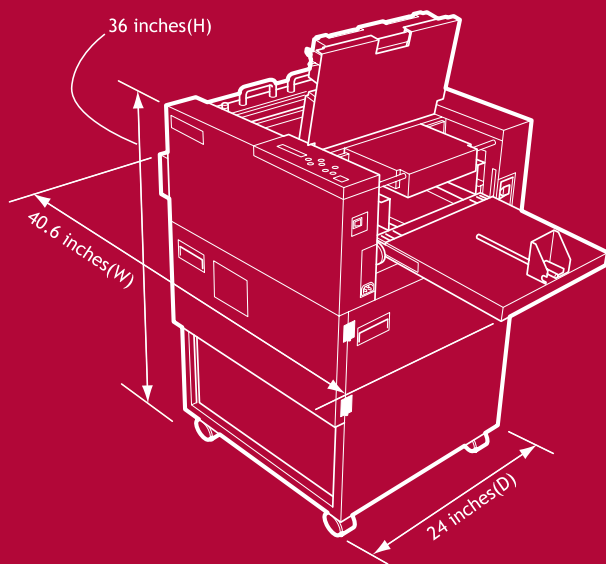

Morgana

3909 Upland Way, Marietta, GA 30066, Georgia, USA

Tel: 866 463 5060 Fax: 770 565 6163

www.morganausa.com

email: morganausa@comcast.net

*As part of our continued product improvement plan, specifications and information published here are subject to change without notice. All specifications are dependent on application, type of stock, temperature, RH and print engine used. Specifications quoted were measured on uncoated and unprinted stock. E & OE.

CardXtra Brochure Ver001 USA September 2009

Irony Plc.
39 The Heights Lane
Woodstock, JH 37806
USA
Tel: +3 (256) 867 4365
Fax: +3 (256) 565 6163
Mobiles:
US: (256) 779-8271
UK: +3 (256) 301-3511
e-mail: elieendover@irony.co.uk
www.irony.co.uk

Morgana
DIGITAL FINISHING FOR DIGITAL PRINTERS
WWW.MORGANAUSA.COM

New CardXtra



Auto Cutting System

Increase productivity and reduce workload with the New CardXtra from Morgana.

Handles paper sizes up to 12" x 19"

Engineered to accept 12" x 19" paper and accurately cut small, medium and high volumes of paper/card automatically.

High speed processing

The machine cuts 12" x 19" paper and card at the rate of 7 sheets per minute. This means that it can cut 140 business cards per minute.

Highly flexible

The CardXtra accepts a wide range of substrate types from wood free paper, wood fibre paper through to uncoated & gloss papers from a digital or litho print process.

It can cut various paper sizes from 9" to 19" and from *0.0048" to 0.016" in thickness.

Highly accurate

High sensitivity sensors monitor the entire cutting process from paper input to paper output. Cutting mark sensors detect cut position marks for highly accurate cutting and making allowance for image drift on digital print engines.



Cutting Layouts for various size sheets

12" x 18"

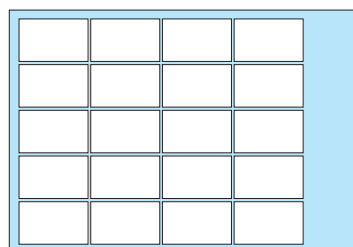

20 x business cards
(with trimming margins)

9" x 12"

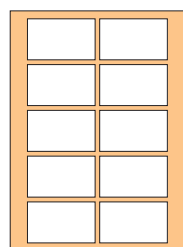

10 x business cards
(with trimming margins)

12" x 18"

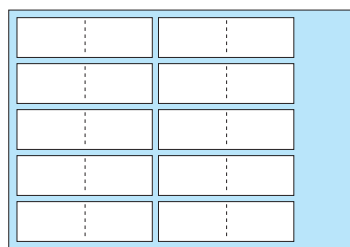

10 x double size business cards
(with trimming margins)

Air feed paper feed system

Up to 500 sheets (0.0048" thick) can be placed in the feed unit of the CardXtra. The use of air suction to pick up the sheets eliminates marking on printed surfaces.

Image drift

The CardXtra compensates for image drift by using a unique registration mark. Once this mark is detected image accuracy is maintained without any loss of speed.

Large capacity paper output tray

The paper output tray accommodates stacks of up to 650 sheets of business cards (0.0048" thickness) in each row.

Front control panel for quick and easy operation

The LCD control panel and touch keys at the front of the CardXtra make it quick and easy to program the machine for repeat jobs with or without the unique registration mark.

Low maintenance and blade replacement

The CardXtra has a very low maintenance cycle. Replacement cutters are plug and play. Cleaning is very quick and simple with easy access to the rollers and waste bin.

The long fixed cross blade and rotary blades are guaranteed for *1,000,000 cuts and 100,000 sheets of 12" x 19" paper respectively.

*This varies with paper quality and condition of the printed surface.



Large capacity waste container

A large capacity waste container is mounted in the lower part of the CardXtra body. This minimises the amount of down time to clear the waste.

Setup and walk away

Once the CardXtra is running you can get on with other jobs. The sensors monitor the operation and the machine will stop if an error is detected or the machine needs more sheets in the feed unit.